

## Performance Measurement of Digital Modulation Schemes Using FPGA

Monika Choudhari<sup>1</sup>, Dr. S. R. Patil<sup>2</sup>

<sup>1,2</sup>Department of Electronics and Telecommunication Engineering <sup>1,2</sup>Bharati Vidyapeeth's College of Engineering for Women's Pune Pune, India

---

**Abstract:** Nowadays, we hardly find any field which is not advancing rapidly, modern communication systems are also advancing at a faster rate. So it is mandatory we must design the techniques to evaluate the performance of such modern communication systems like Software Defined Radio (SDR), Cognitive Radio using reconfigurable devices like FPGA. This paper presents the technique for the performance measurement of digital modulation schemes since the digital modulation schemes are superior as compared to analogue modulation schemes. The performance characteristics like bit error rate (BER), SNR, SNDR can be used to evaluate the performance of digital modulation techniques. Bit error rate (BER) is the principle measure of performance of a data transmission link. The system will be able to measure the performance of more than one modulation scheme. This paper presents the results of BER for digital modulation schemes; Verilog HDL is used to implement the proposed techniques.

**Keyword—** Bit Error Rate (BER), signal to noise ratio (SNR), signal to noise and distortion ratio (SNDR), software defined radio (SDR), field programmable gate array (FPGA).

---

### I. INTRODUCTION

The wireless system development using the latest communication techniques is increasingly limited by the design productivity. It is critical to verify the design characteristics at the earliest possible stage of design to minimize costly design iterations. At the physical (PHY) layer, the bit error rate (BER) performance metric is widely used to measure the reliability of the communication systems. Monte Carlo (MC) simulation techniques have been widely used to generate BER versus a range of expected signal-to-noise ratio (SNR) conditions. However, the execution times of software-based MC simulations of the baseband layer on workstations can be extremely long, especially for increasingly complex communication systems [1].

Digital modulation technology is an important content of modern communication. Modulation is essential in transmitting two or more signals in the same time because avoids interference between the signals and also ensure that errors are avoided during transmission. In order to transmit the digital information is as a series of ones (1) and zeros (0) over long distances, different modulation schemes are used which are Binary Phase Shift Keying (BPSK), Binary Amplitude Shift Keying (BASK), Frequency Shift Keying (BFSK), Quadrature Phase Shift Keying (QPSK). The bit error rate (BER) performance metric is widely used to measure the reliability of the communication systems. Bit error rate (BER) is the ratio between the numbers of error bits received to the total number of bits received. The design of an all-digital, binary-phase-shift-keying (BPSK) demodulator is described, the project details the design of the components (e.g., Booth multipliers and pseudorandom noise (PN) generators) and the simulation of the entire system [2].

The rest of this paper is organized as follows. Section II briefly presents the different digital modulation schemes. Section III presents the implementation BER measurement process. Sections IV and V presents the implementation and simulation results and applications respectively. Finally, Section VI makes some concluding remarks with section VII discussing future scopes for the system.

### II. DIFFERENT DIGITAL MODULATION SCHEMES

#### A. Binary Phase Shift Keying

In a BPSK, the phase of the sinusoidal carrier signal is changed according to the message while keeping the amplitude and frequency constant (Fig.1).

#### B. Binary Amplitude Shift Keying

In a Binary Amplitude-Shift keying, the amplitude of the sinusoidal carrier signal is changed according to the message level, while keeping the frequency and phase constant (Fig.2).

**C. Binary Frequency Shift Keying**

In a BFSK modulation process, the frequency of the sinusoidal carrier signal is changed according to the message level. It keeps the amplitude and phase constant (Fig.3).

**III. IMPLEMENTATION OF BER MEASUREMENT PROCESS**

The proposed system is having the modulator and demodulator for the digital modulation schemes which are implemented using Verilog Hardware Description Language. The simulation of the BER calculation is done using the MATLAB software. For verification and synthesis of the Verilog codes of modulation schemes XILINX ISE Simulator has been used. The implementation of this synthesized code has been done on Spartan3 FPGA hardware kit.

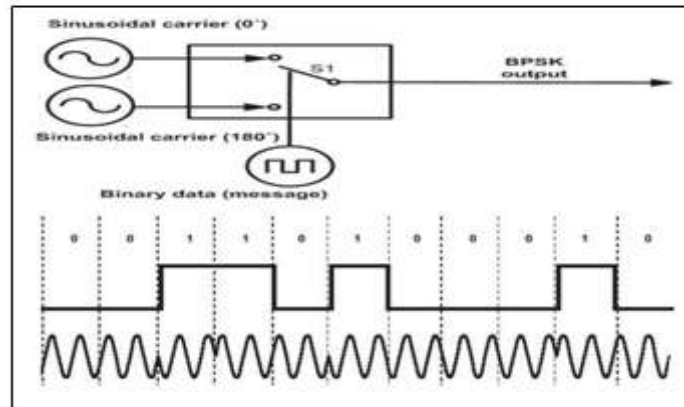

Fig. 1 Basic circuit and waveform of BPSK Modulation

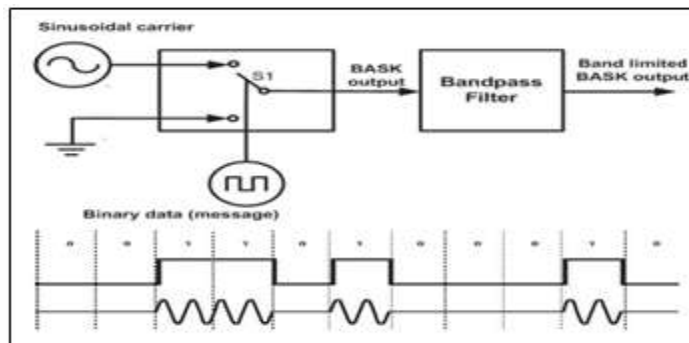

Fig. 2 Basic circuit and waveform of BASK Modulation

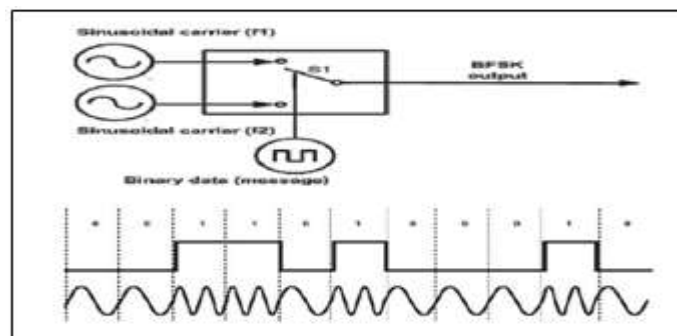

Fig. 3 Basic circuit and waveform of BFSK Modulation

**IV. RESULTS**

The results of work done are given in this section. The RTL schematic for BASK modulation is shown in Fig. 4 with device utilization for the same is shown in Fig. 5. Technology schematic for BASK is represented in Fig. 6. The RTL schematic for BPSK modulation is shown in Fig. 7 with device utilization for the same shown in Fig. 8. Technology schematic for BPSK is represented in Fig. 9. The RTL schematic for QPSK modulation is shown in Fig. 10 with device utilization for the same shown in Fig. 11. Technology schematic for QPSK is

represented in Fig. 12. Simulation results for BER of BPSK modulation are presented in fig. 13. Simulation results for BER of QPSK modulation are presented in fig. 14.

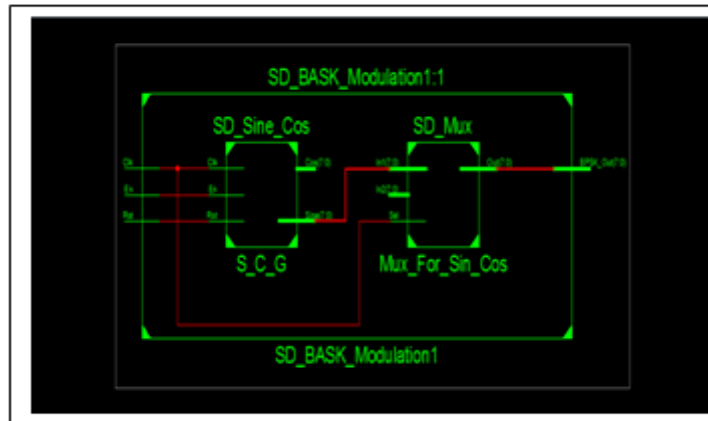

Fig. 4 RTL schematic for BASK modulation

Device Utilization Summary				
Logic Utilization	Used	Available	Utilization	Note(s)
Number of Slice Flip Flops	16	3,840	1%	
Number of 4 input LUTs	32	3,840	1%	
Number of occupied Slices	16	1,920	1%	
Number of Slices containing only related logic	16	16	100%	
Number of Slices containing unrelated logic	0	16	0%	
Total Number of 4 input LUTs	32	3,840	1%	
Number of bonded IOBs	11	97	11%	
Number of BUFGMUXs	1	8	12%	
Average Fanout of Non-Clock Nets	2.44			

Fig. 5 Device utilization summary for BASK Modulation

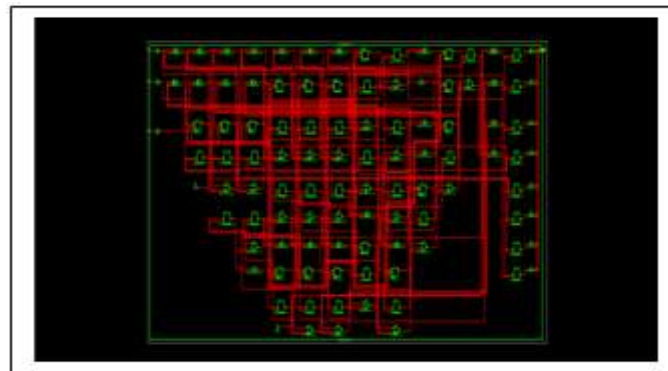

Fig. 6 Technology schematic for BASK Modulation

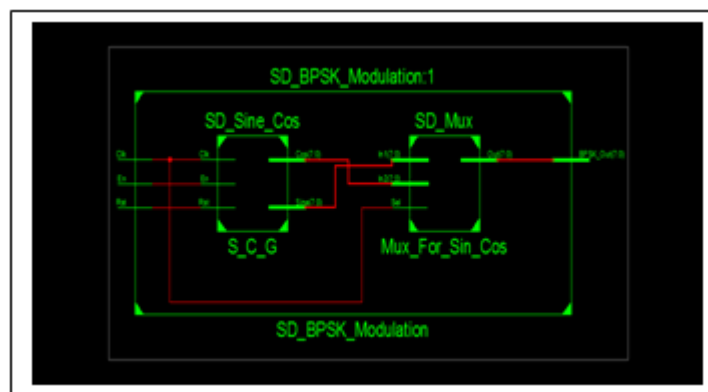

Fig. 7 RTL schematic for BPSK modulation

Device Utilization Summary				
Logic Utilization	Used	Available	Utilization	Note(s)
Number of Slice Flip Flops	16	3,840	1%	
Number of 4 input LUTs	40	3,840	1%	
Number of occupied Slices	20	1,920	1%	
Number of Slices containing only related logic	20	20	100%	
Number of Slices containing unrelated logic	0	20	0%	
Total Number of 4 input LUTs	40	3,840	1%	
Number of bonded IOBs	11	97	11%	
Number of BUFMGUs	1	8	12%	
Average Fanout of Non-Clock Nets	2.44			

Fig. 8 Device utilization summary for BPSK Modulation

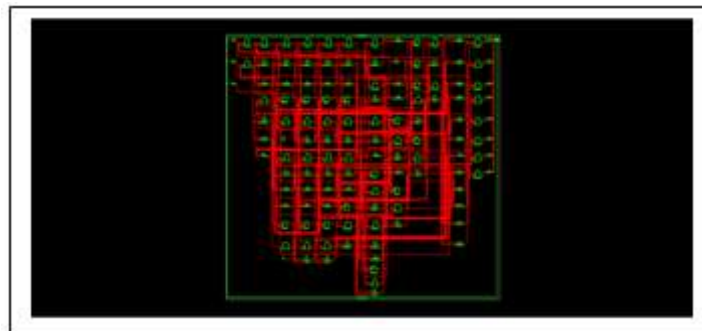

Fig. 9 Technology schematic for BPSK Modulation

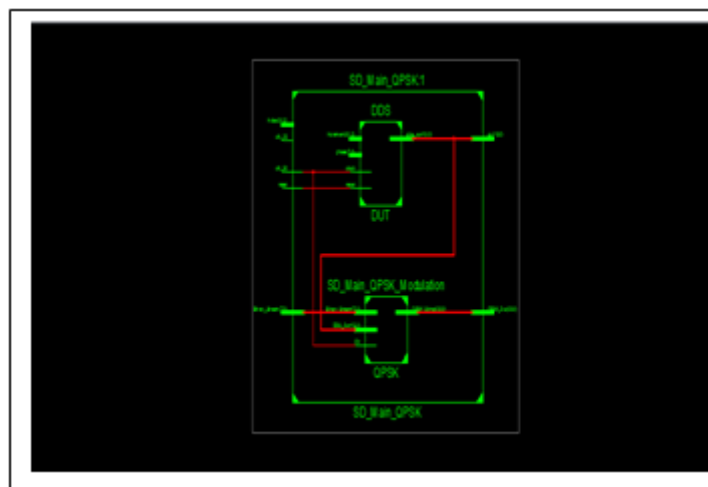

Fig. 10 RTL schematic for QPSK modulation

Device Utilization Summary				
Logic Utilization	Used	Available	Utilization	Note(s)
Number of Slice Flip Flops	13	3,840	1%	
Number of 4 input LUTs	25	3,840	1%	
Number of occupied Slices	22	1,920	1%	
Number of Slices containing only related logic	22	22	100%	
Number of Slices containing unrelated logic	0	22	0%	
Total Number of 4 input LUTs	25	3,840	1%	
Number of bonded IOBs	47	97	48%	
Number of RAMB16s	1	12	8%	
Number of MULT18X18s	2	12	16%	
Number of BUFMGUs	1	8	12%	
Average Fanout of Non-Clock Nets	1.47			

Fig. 11 Device utilization summary for BASK Modulation

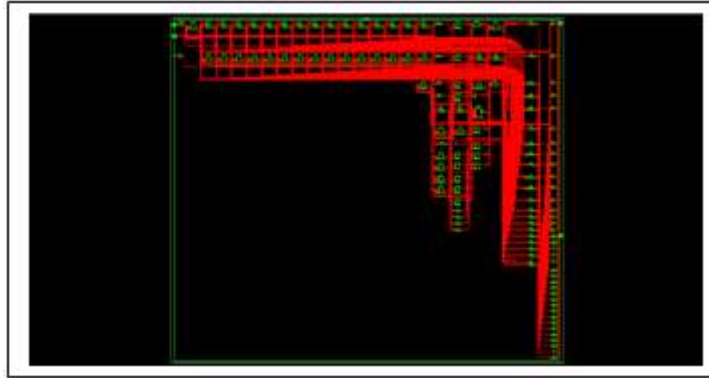

Fig. 12 Technology schematic for QPSK Modulation

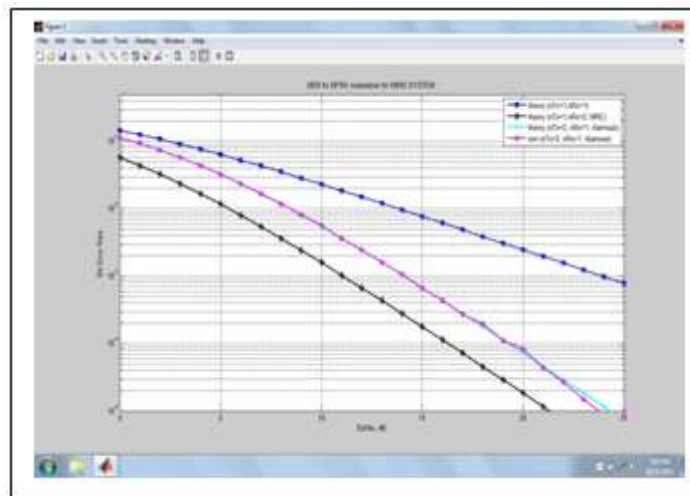

Fig. 13 BER simulation results for BPSK modulation

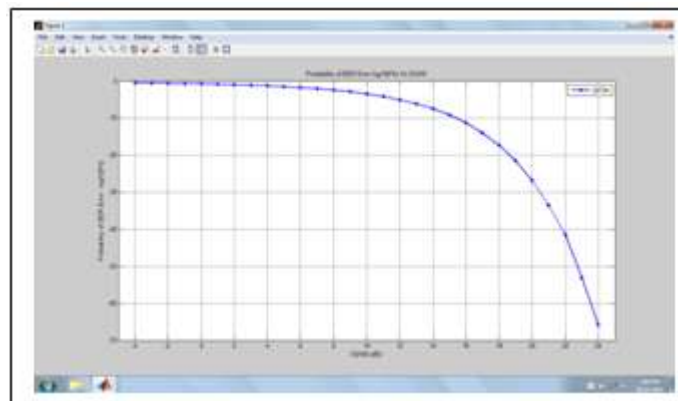

Fig. 14 BER simulation results for QPSK modulation

## V. APPLICATIONS

The system has the applications for the measurement of performance and checking the reliability of the networks like

Commercial Communication Systems, Wireless Communication Systems, Optical Networks, Software Defined Radios and many more.

## VI. CONCLUSION

The system has many advantages because of the use of its implementation on FPGA like gives fast results and reconfigurable design since using FPGA, productivity increases since time of design is reduced, cost is less as compared to conventional performance measurement methods.

It consumes less power.

## VII. FUTURE SCOPE

The system can be implemented as a standalone system with implementation of all modulation schemes as well as calculations of BER on a single FPGA. This system can be used to measure more than one performance parameters for the advanced modulation schemes which are presently used in modern communication systems.

## REFERENCES

- [1.] Amirhossein Alimohammad and Saeed Fouladi Fard, "FPGA-Based Bit Error Rate Performance Measurement of Wireless Systems," *IEEE Trans. on Very Large Scale Integration (VLSI) Systems*, VOL. 22, NO. 7, JULY 2014
- [2.] Faruque Ahamed, and Frank A. Scarpino, "An Educational Digital Communications Project Using FPGAs to Implement a BPSK Detector," *IEEE Trans. on Education*, VOL. 48, NO. 1, FEBRUARY 2005
- [3.] Kaliprasanna Swain & Manoj Kumar Sahoo, "FPGA Implementation of QPSK Modulator Based on Matlab/Xilinx System Generator," *International Conference on Recent Innovations in Engineering & Technology*, April 2014
- [4.] Devanshi S. Desai, Dr. Nagendra P. Gajjar, "Low Bit-rate Modulator Using FPGA," *International Journal of Electronics And Communication Engineering & Technology*, Vol. 5, Issue 4, April 2014
- [5.] T. K. Zombade, S. A. Shirsat, "QPSK Modem using FPGA," *International Journal of Electronics Communication and Computer Engineering*, Volume 5, April, 2014
- [6.] Mrs. Varsha Patil, Dr. M.S. Sutaone, "Simulink and System Generator Blockset for FPGA Implementation of the Digital Modulation Schemes," *International Journal of Advanced Engineering Science and Information Technology*, Vol.1, Issue 1, January 2014
- [7.] Molabanti Praveen Kumar, T.S.R Krishna Prasad, M Vijaya Kumar, "Implementation of Digital Communication Laboratory on FPGA," *International Journal of Advanced Research in Computer and Communication Engineering* Vol. 2, Issue 11, November 2013
- [8.] Hyun-Bae Jeon, Jong-Seon No, and Dong-Joon Shin, "A New PAPR Reduction Scheme Using Efficient Peak Cancellation for OFDM Systems," *IEEE Tran. on Broadcasting*, VOL. 58, NO. 4, DECEMBER 2012
- [9.] Yu-Sun Liu, "Diversity-Combining and Error-Correction Coding for FFH/MFSK Systems over Rayleigh Fading Channels under Multitone Jamming," *IEEE Trans. on Wireless Communications*, VOL. 11, NO. 2, FEBRUARY 2012
- [10.] Joaquin Garcia, Rene Cumplido, "On the design of an FPGA-Based OFDM modulator for IEEE 802.11a," *International Conference on Electrical and Electronics Engineering*, September, 2005.